

THIS DRAWING IS UNPUBLISHED. RELEASED FOR PUBLICATION
 © COPYRIGHT BY TYCO ELECTRONICS CORPORATION. ALL RIGHTS RESERVED.

LOC	DIST	REVISIONS					
FT	0	P	LTR	DESCRIPTION	DATE	DWN	APVD
		F		REVISED PER 0G3B-1175-04	12/22/04	SS	GS

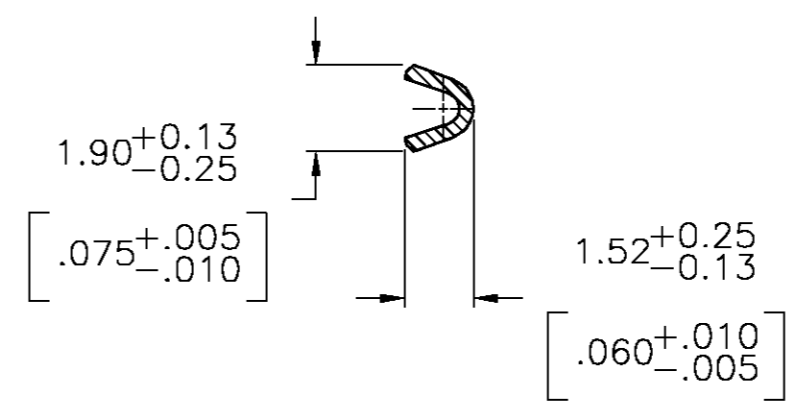

SECTION B-B

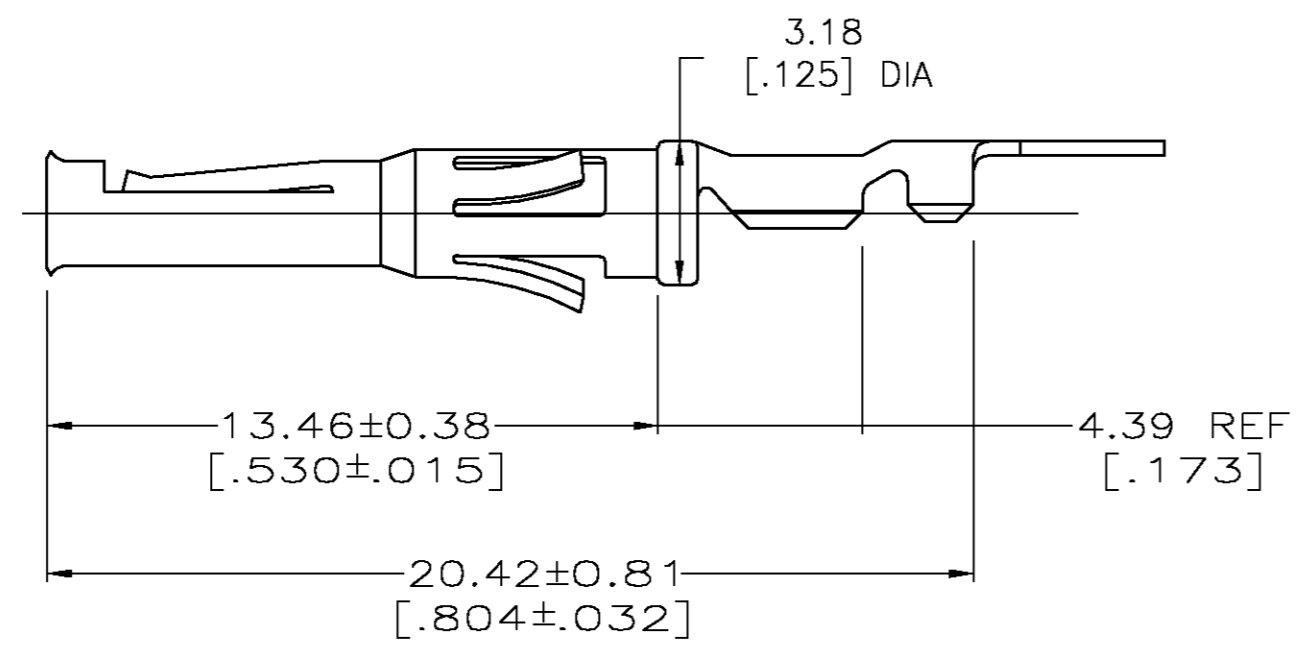
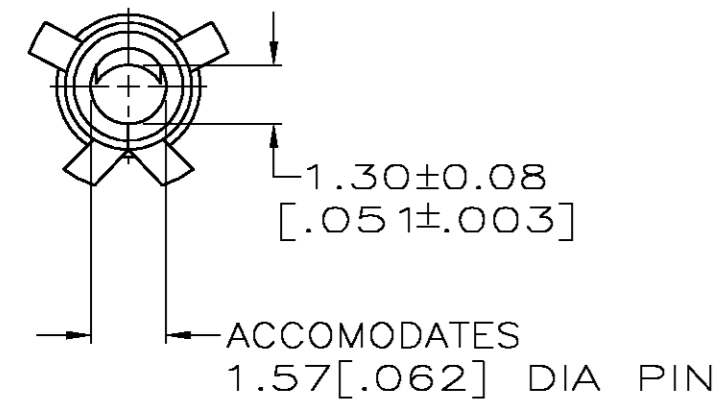
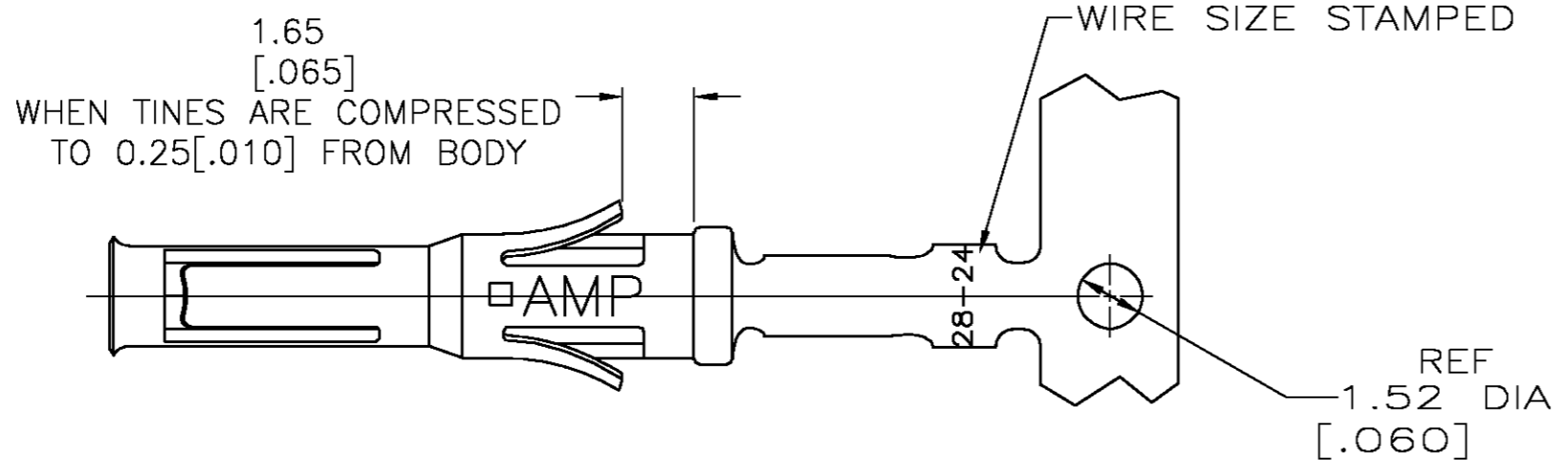
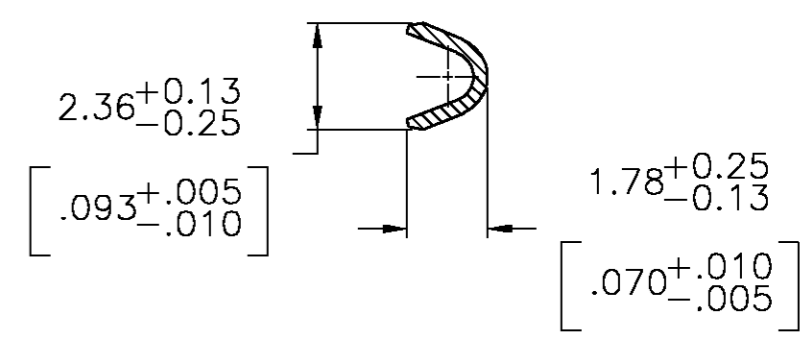

SECTION A-A

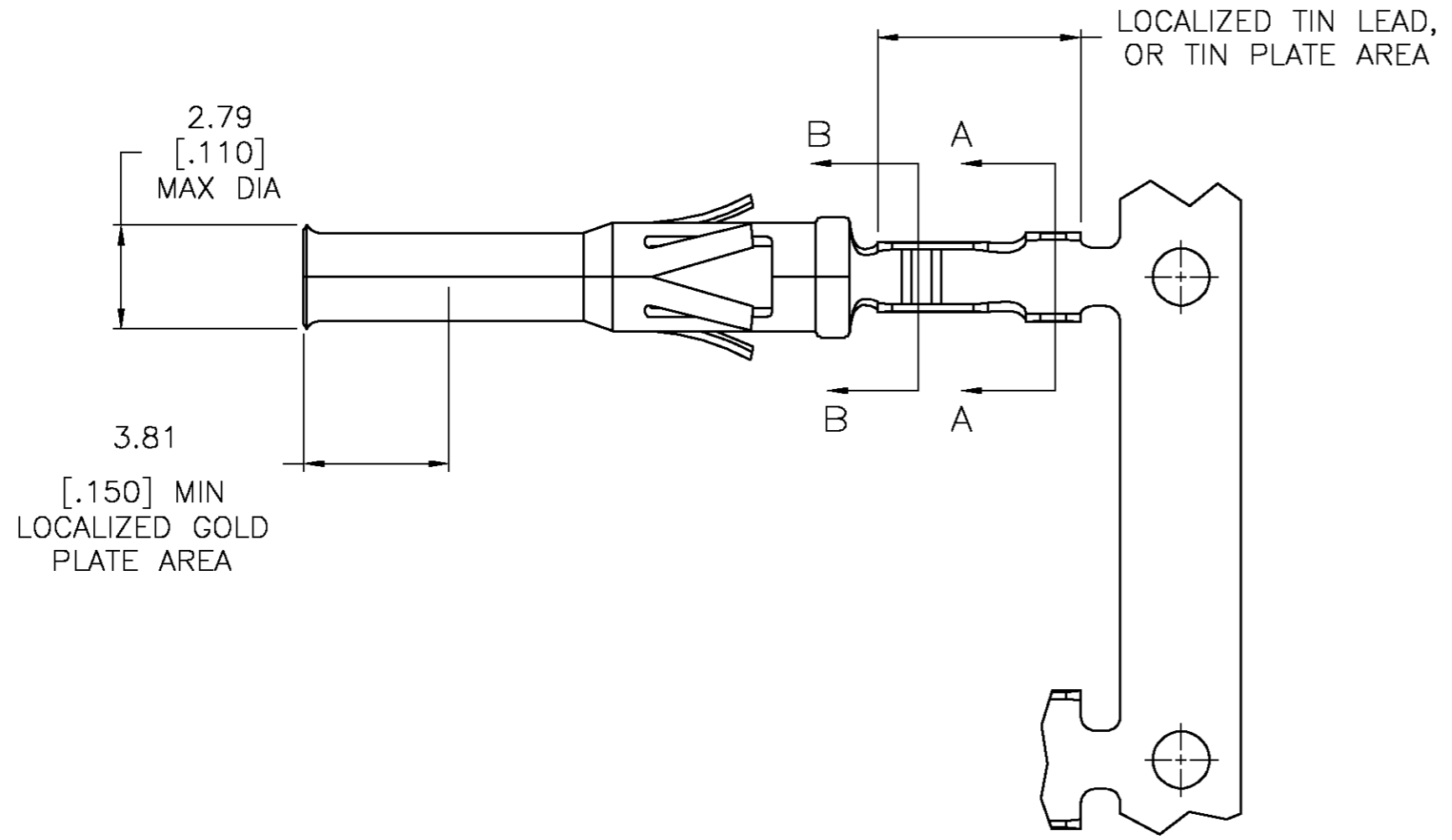

1. WIRE RANGE 28-24 AWG.
 2. INSULATION RANGE 0.89-1.40[.035-.055] DIA.
 3. FOR LOOSE PIECE PART SEE DWG 66596.
- 4 0.76um [.000030] MIN GOLD IN LOCALIZED GOLD PLATE AREA, 1.27um [.000050] MIN TIN-LEAD IN LOCALIZED TIN-LEAD PLATE AREA, BOTH OVER 1.27um [.000050] MIN NICKEL.
 - 5 TIN PLATED.
 - 6 GOLD PLATING PER MIL-G-45204, TIN PER MIL-T-10727 AND NICKEL PER QQ-N-290.
 - 7 0.76um [.000030] MIN GOLD IN LOCALIZED GOLD PLATE AREA, 1.27um [.000050] MIN TIN IN LOCALIZED TIN PLATE AREA, BOTH OVER 1.27um [.000050] MIN NICKEL.

DESCRIPTION	FINISH	PART NO.
REVERSE REELED FOR MINI-APPICATOR	7	66586-5
REVERSE REELED FOR MINI-APPICATOR	4	66586-4
-	4	66586-3
OBSOLETE REVERSE REELED FOR MINI-APPICATOR	5	66586-2
OBSOLETE -	5	66586-1

THIS DRAWING IS A CONTROLLED DOCUMENT.		DWN D.HARDY 06/15/94	Tyco Electronics Corporation Harrisburg, Pa 17105-3608	
DIMENSIONS: mm [INCHES]		CHK R.STONE 06/22/94	NAME CONTACT, SOCKET, STRIP, TYPE VI, MULTIMATE	
TOLERANCES UNLESS OTHERWISE SPECIFIED:		APVD -	SIZE A2	
0 PLC ± -		PRODUCT SPEC -	CAGE CODE 00779	
1 PLC ± -		APPLICATION SPEC -	DRAWING NO C=66586	
2 PLC ± 0.13 [.005]		WEIGHT -	RESTRICTED TO -	
3 PLC ± -		FINISH SEE TABLE 6	SCALE 6:1	
4 PLC ± -		MATERIAL BRASS PER MIL-C-50	SHEET 1 OF 1	
ANGLES ± -		CUSTOMER DRAWING	REV F	
FINISH		CUSTOMER DRAWING		